

D3-110I-D, D3-110I-E, D3-110I-F, D3-140I-E, D3-140I-F, D3-140A-D, D3-140A-E, D3-140A-F, D3-150I-D, D3-150I-E, D3-150I-F, D3-170I-D, D3-170I-E, D3-170I-F, D3-170A-D, D3-170A-E, D3-170A-F, D3-200I-D, D3-200I-E, D3-200I-F, D3-200A-D, D3-200A-E, D3-200A-F, D3-220I-D, D3-220I-E, D3-220I-F, D3-220A-D, D3-220A-E, D3-220A-F

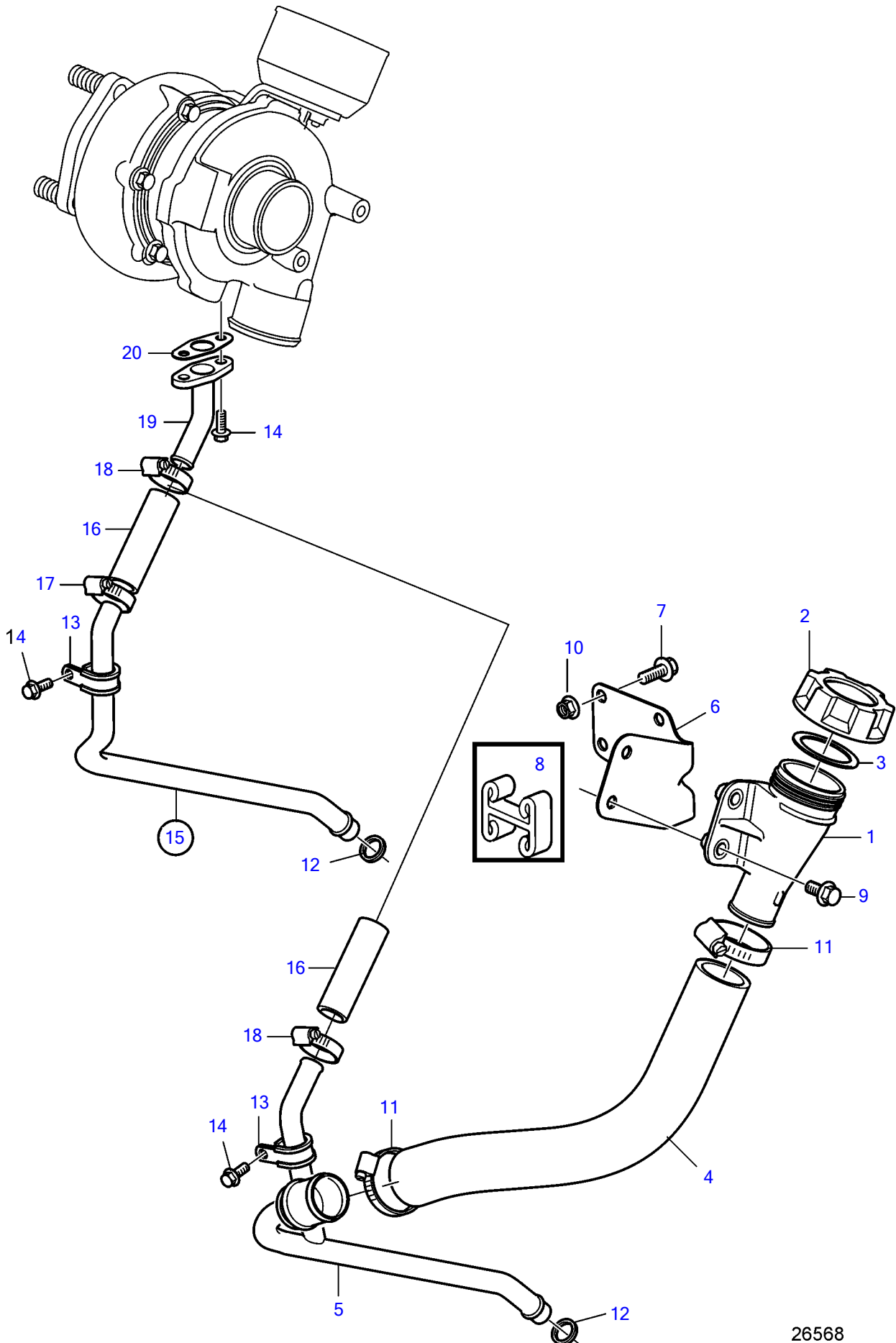

26568

D3-110I-D, D3-110I-E, D3-110I-F, D3-140I-E, D3-140I-F, D3-140A-D, D3-140A-E, D3-140A-F, D3-150I-D, D3-150I-E, D3-150I-F, D3-170I-D, D3-170I-E, D3-170I-F, D3-170A-D, D3-170A-E, D3-170A-F, D3-200I-D, D3-200I-E, D3-200I-F, D3-200A-D, D3-200A-E, D3-200A-F, D3-220I-D, D3-220I-E, D3-220I-F, D3-220A-D, D3-220A-E, D3-220A-F

REF	PART NO.	QTY	DESCRIPTION	NOTES
1	20808091	1	Oil filler pipe	
2	20807510	1	• Oil filler cap	
3	20365079	1	• • Rubber washer	
4	21711255	1	Hose	
5	21177977	1	Oil return pipe	Option
6	21194093	1	Bracket	Replaced by 21353908
	21353908	1	Bracket	With weld nuts
7	946173	4	Flange screw	M8x20mm
	965180	4	Flange screw	For inboard
8	21369356	1	Profile	For inboard
9	946440	2	Flange screw	M8x16mm
10	945408	4	Flange nut	
11	961669	2	Hose clamp	
12	31251439	1	Sealing ring	
13	952629	1	Clamp	
14	946544	4	Flange screw	M6x16mm
15	21294908	1	Oil return pipe	Standard
16	3593534	1	• Hose	
17	961665	1	• Hose clamp	
18	961665	1	Hose clamp	
19	21098797	1	Oil return pipe	
20	31251456	1	Gasket	